



#### STANDARD

- Our enclosures/ pillar boxes, are all generally made from 3mm Cold rolled steel,
- Plasma cut or Laser cut,
- All Galvanised! the Base section is also Bitumen painted for extra protection.
- The Base is a separate section that can be fitted in place at groundworks stage, with service ducts etc in place, ready to accept the Enclosure/pillar later.
- Cell sponge rubber seals.
- ¼ turn cam locks-chrome,
- Doors on all units open round to **185 degrees**, to allow good access.
- All units are fitted with Marine plywood backing board, 12,15,18mm options.
- Safety decal.
- Lifting eyes for safe handling on site.

#### OPTIONAL EXTRA

- Stainless 304, 316 options are available also,
- Hasp & staple, Yale locks are all options that can be used depending on security required.
- ¼ turns with cylinder – Lockable, very tidy & secure. Several different materials/finishes.
- Powder coating either alone or on top of the galv unit is no problem.
- Different backing board options on request.
- Any other requests don't hesitate to ask.

## Contact

### SGS Mechanical

Killybreen,  
Emyvale,  
Monaghan,  
H18 CK12

**Phone:** 0876918435

<https://www.sgsmechanical.ie>

**Email:** [seamus@sgsmechanical.ie](mailto:seamus@sgsmechanical.ie)  
[seamus@sgsmechanical.net](mailto:seamus@sgsmechanical.net)

#### Opening Hours:

08:00-17:30 (Monday-Friday)

08:00-14:00 (Saturday)



| No. | Description        | Width mm | Height mm | Depth mm | Doors | Name              |
|-----|--------------------|----------|-----------|----------|-------|-------------------|
| 1   | Single compartment | 450      | 900       | 250      | 1No   | SC 450,900,250.   |
| 2   | Single compartment | 500      | 1000      | 250      | 1No   | SC 500,1000,250.  |
| 3   | Single compartment | 600      | 1000      | 450      | 1No   | SC 600,1000,450.  |
| 4   | Single compartment | 600      | 1200      | 450      | 1No   | SC 600,1200,450.  |
| 5   | Single compartment | 800      | 1000      | 450      | 1No   | SC 800,1000,450.  |
| 6   | Single compartment | 800      | 1200      | 450      | 1No   | SC 800,1200,450.  |
| 7   | Double compartment | 1000     | 1200      | 450      | 2No   | DC 1000,1200,450. |
| 8   | Double compartment | 1200     | 1200      | 450      | 2No   | DC 1200,1200,450. |
| 9   | Double compartment | 1400     | 1400      | 450      | 2No   | DC 1400,1400,450. |
| 10  | Four compartment   | 1500     | 1500      | 450      | 4No   | 4C 1500,1500,450. |
| 11  | Four compartment   | 1500     | 1500      | 500      | 4No   | 4C 1500,1500,500. |

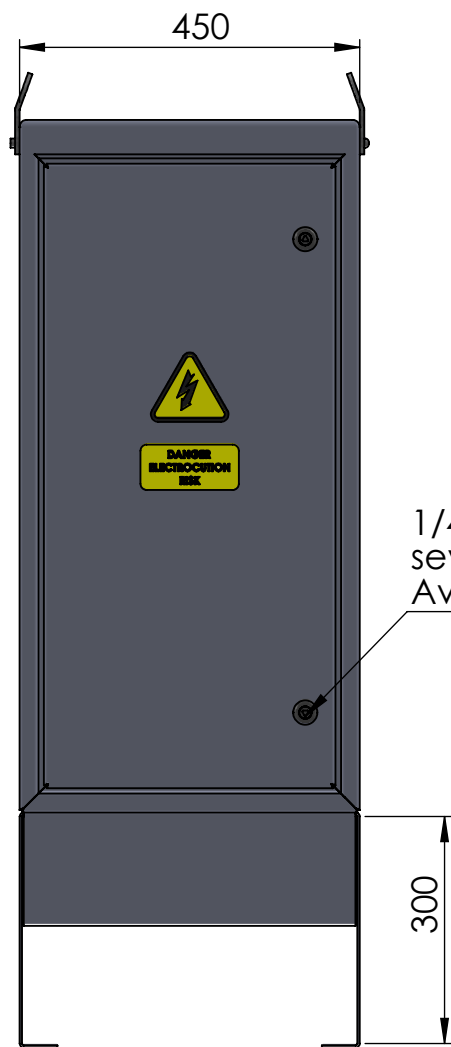
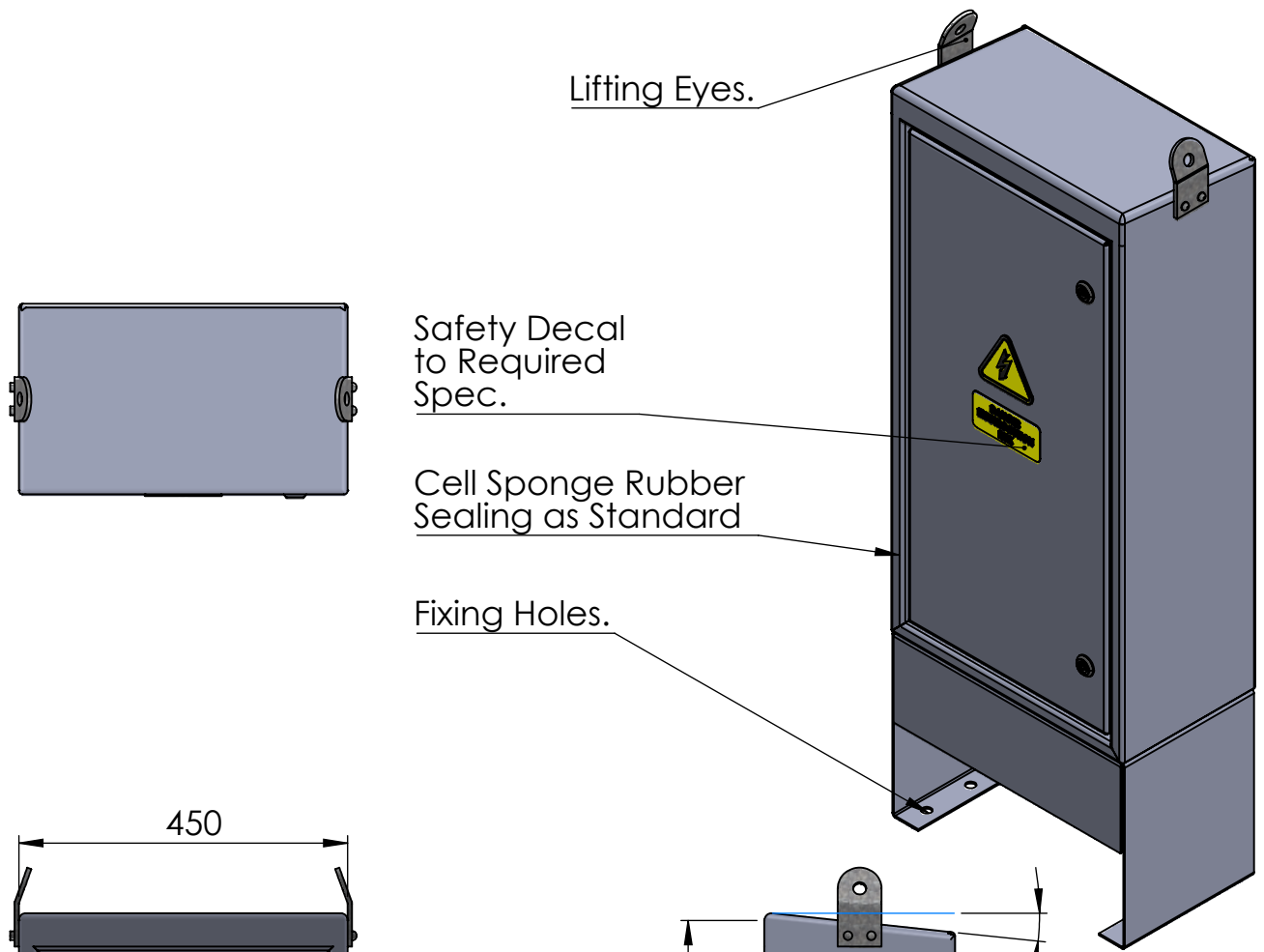

1/4 Turns, several options Available.

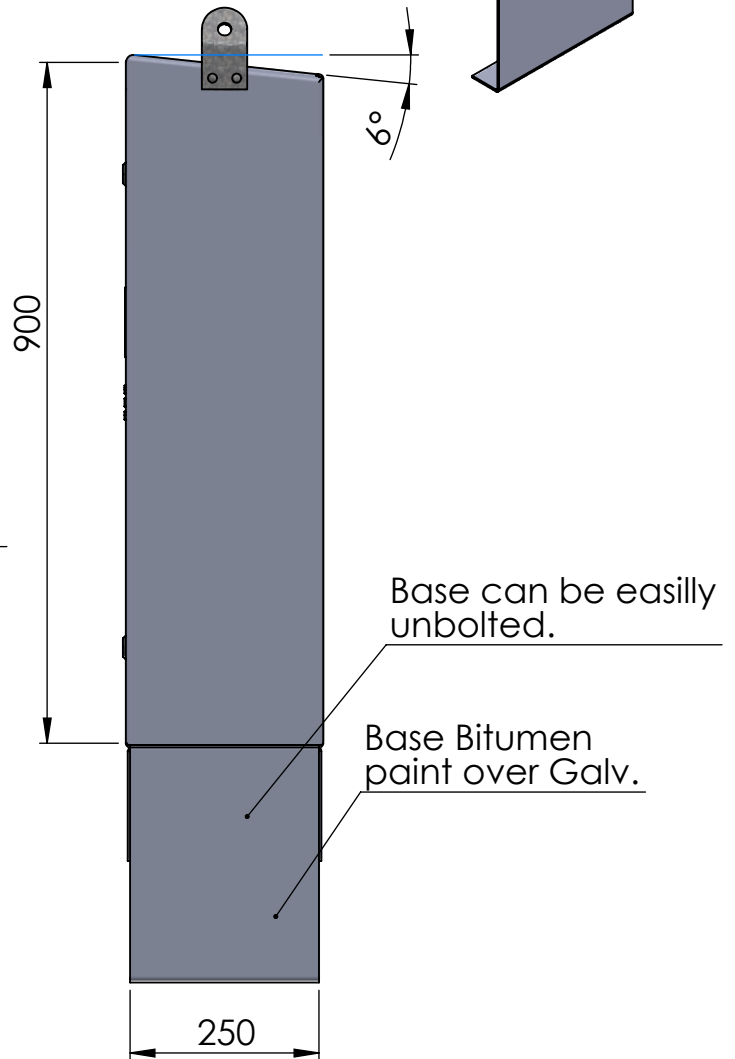

EMAIL: [seamus@sgsmechanical.net](mailto:seamus@sgsmechanical.net)

MOBILE: 0876918435

DESCRIPTION:

SC 450,900,250



MATERIAL:  
See Part Drawing

WEIGHT Kg:  
69.1



Lifting Eyes.

Safety Decal to Required Spec.

Cell Sponge Rubber Sealing as Standard

Fixing Holes.

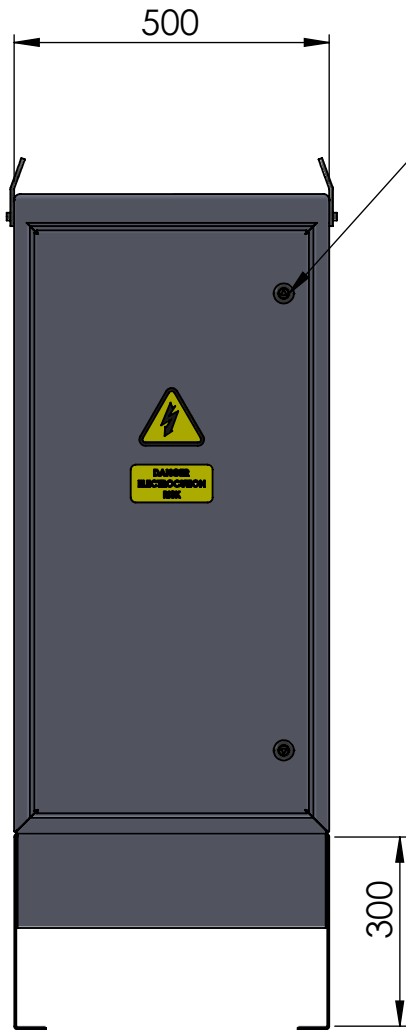
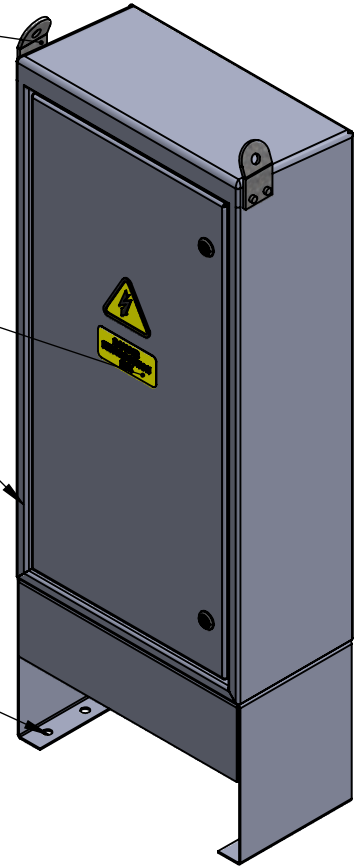

1/4 Turns, several options Available.

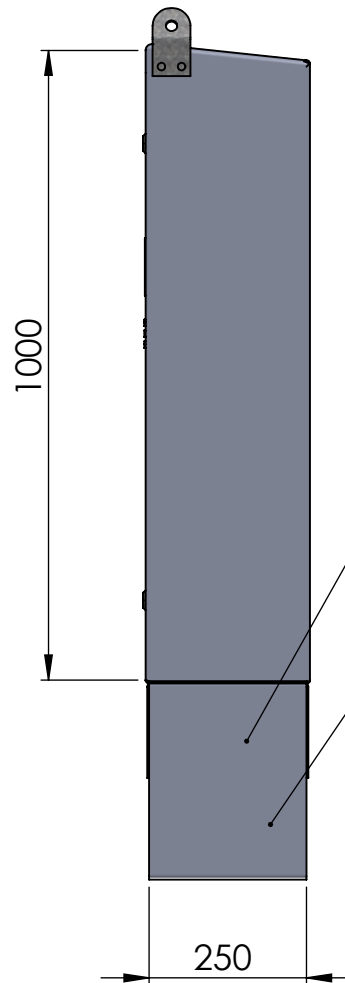

Base can be easily unbolted.

Base Bitumen paint over Galv.

EMAIL: [seamus@sgsmechanical.net](mailto:seamus@sgsmechanical.net)

MOBILE: 0876918435

DESCRIPTION:

SC 500,1000,250.



MATERIAL:  
See Part Drawing

WEIGHT Kg:  
77.7

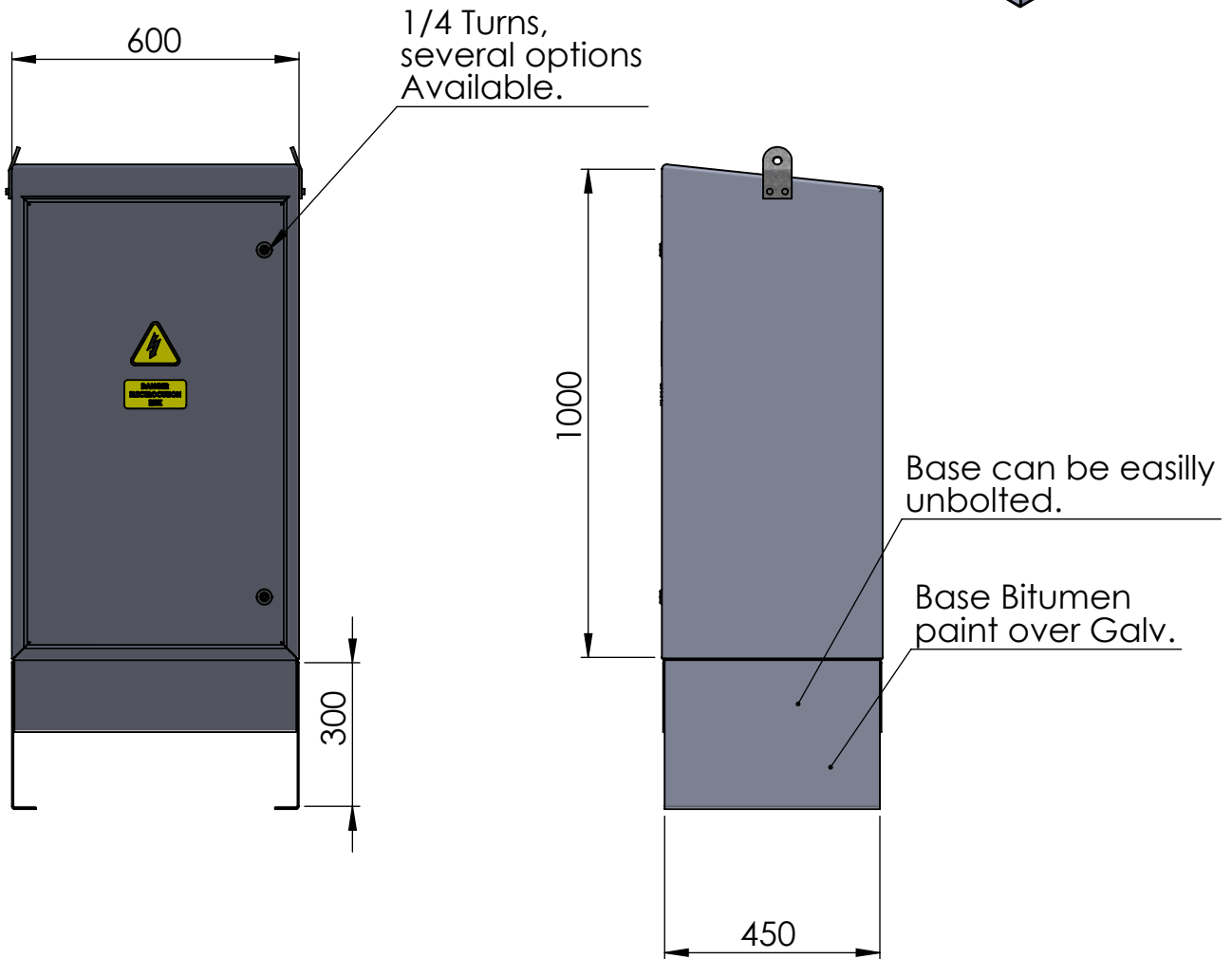
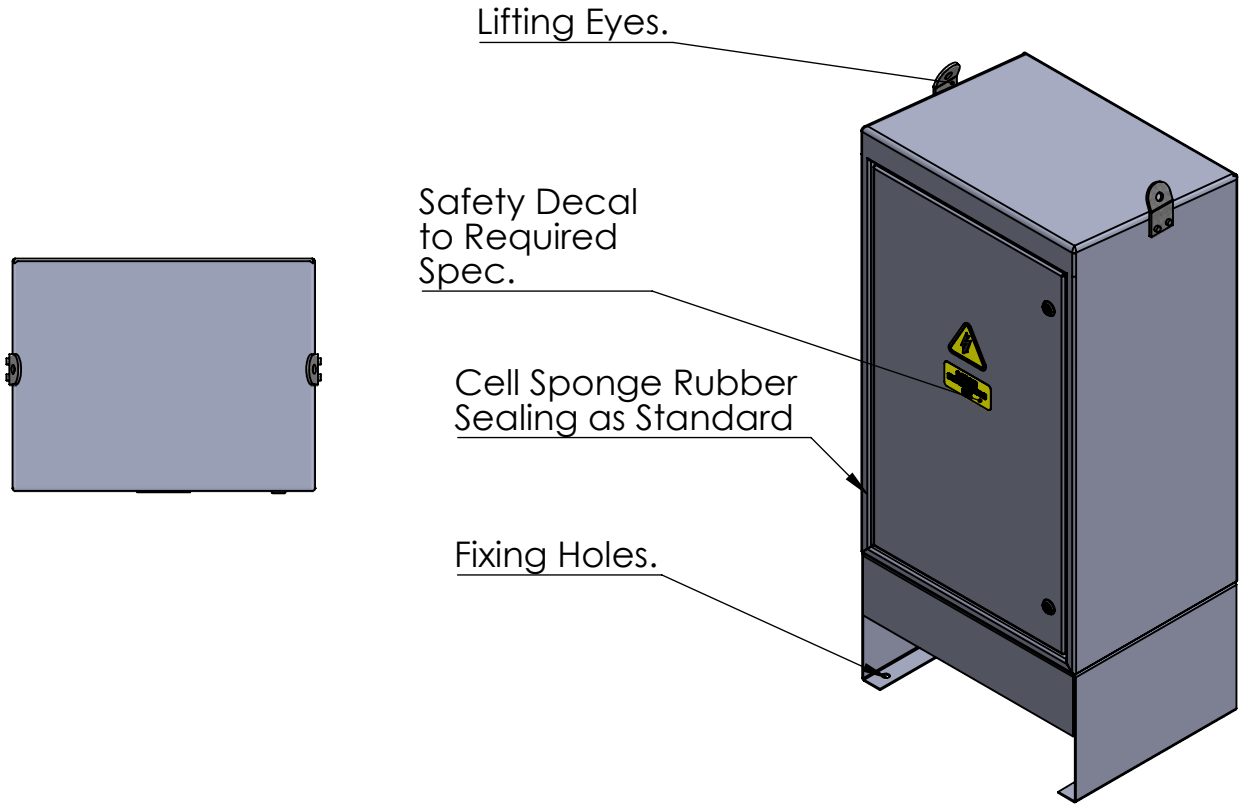

EMAIL: [seamus@sgsmechanical.net](mailto:seamus@sgsmechanical.net)

MOBILE: 0876918435

DESCRIPTION:

SC 600,1000,450.



MATERIAL:  
See Part Drawing

WEIGHT Kg:  
161.5

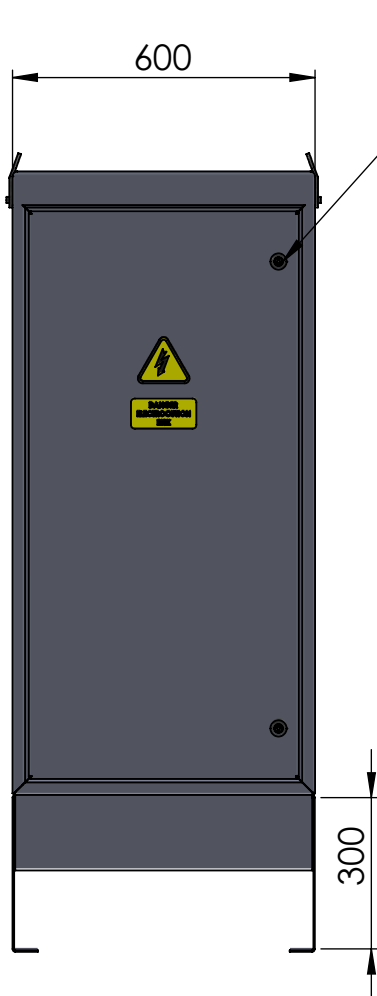
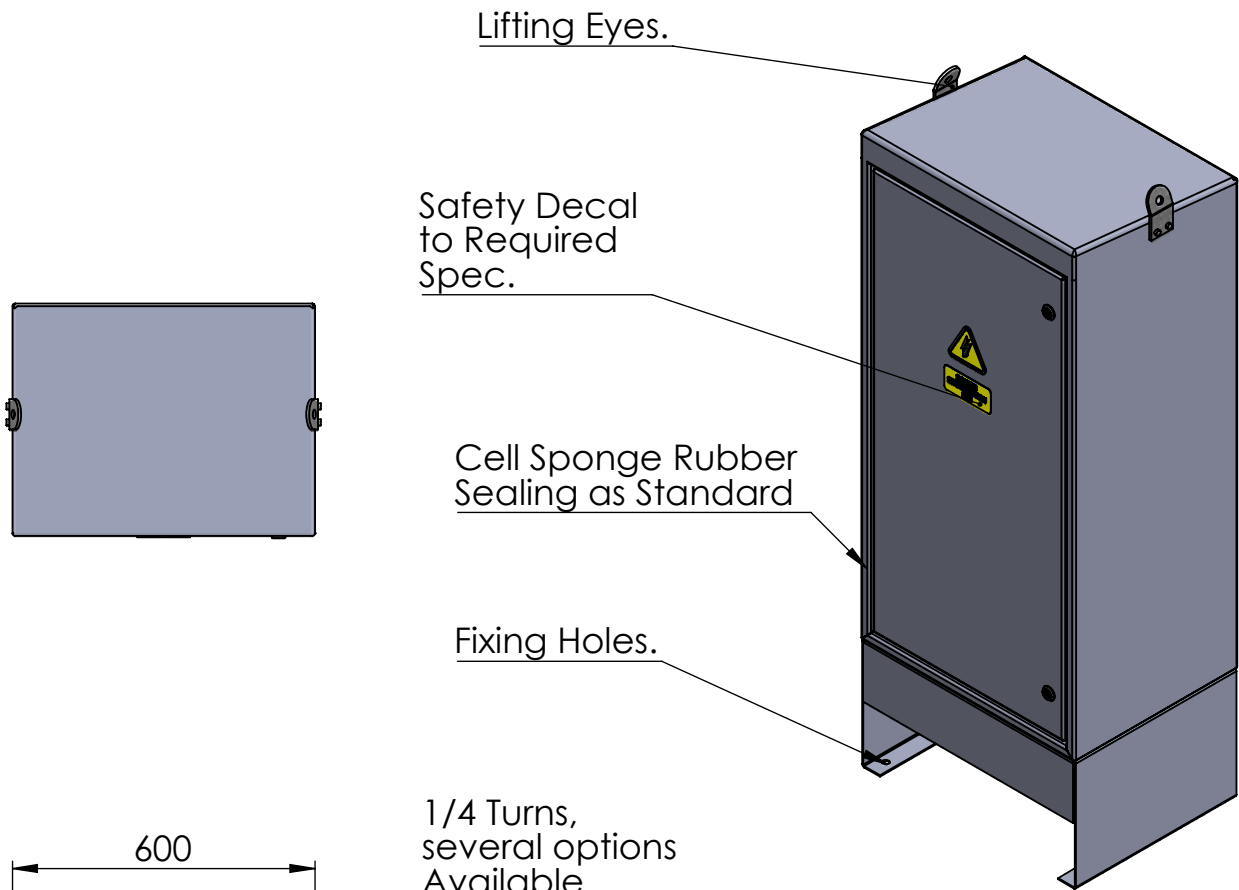

1/4 Turns, several options Available.

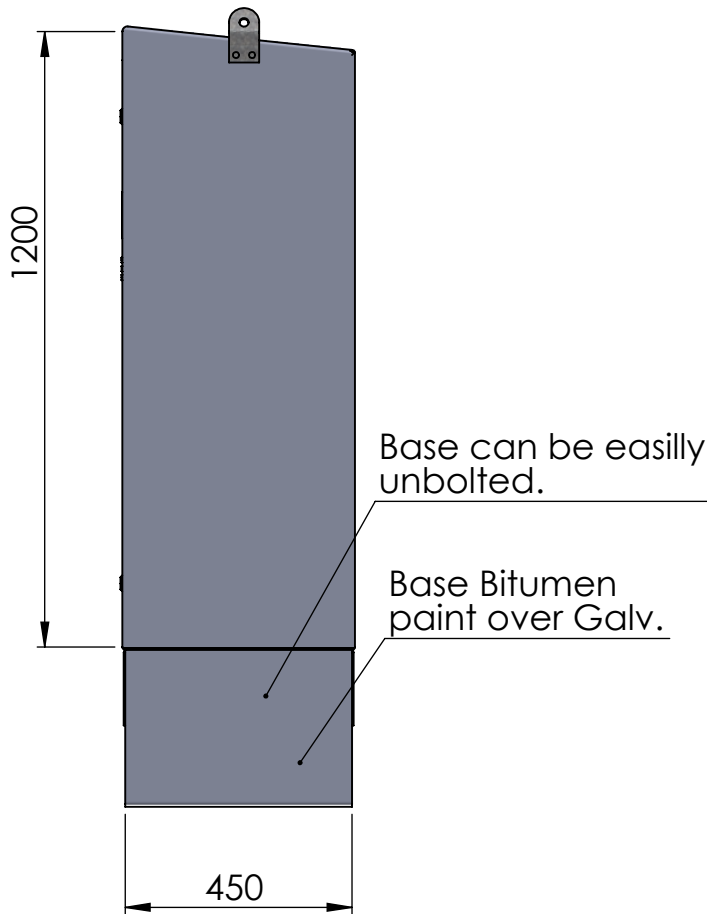

EMAIL: seamus@sgsmechanical.net

MOBILE: 0876918435

DESCRIPTION:

SC 600,1200,450



MATERIAL:  
See Part Drawing

WEIGHT Kg:  
169.8

Lifting Eyes.

Safety Decal to Required Spec.

Cell Sponge Rubber Sealing as Standard

Fixing Holes.

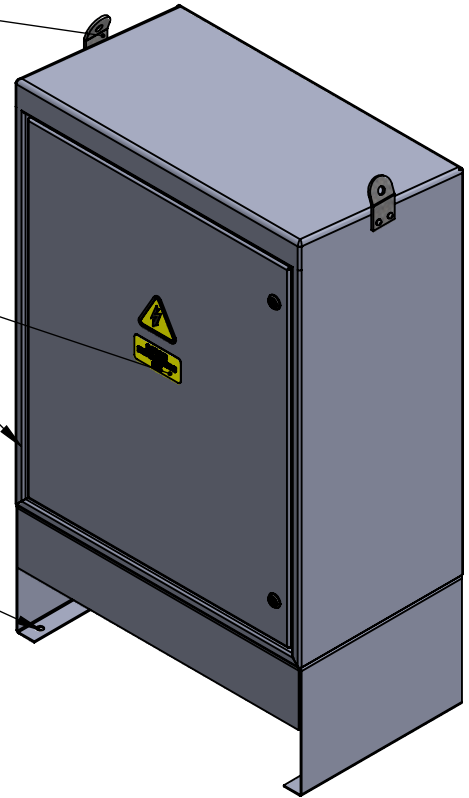
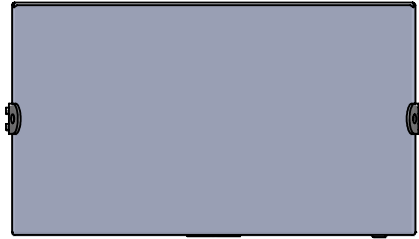

1/4 Turns, several options Available.

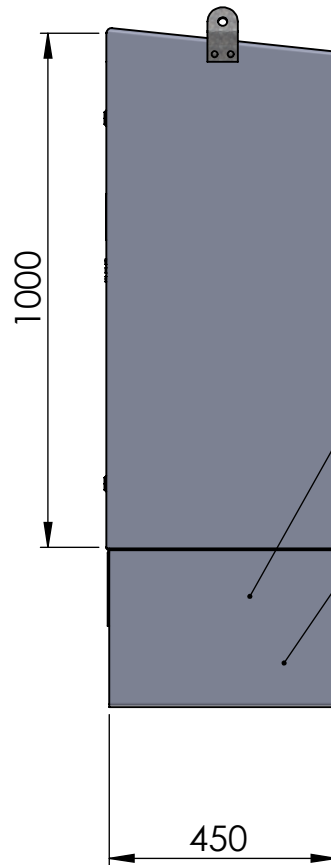
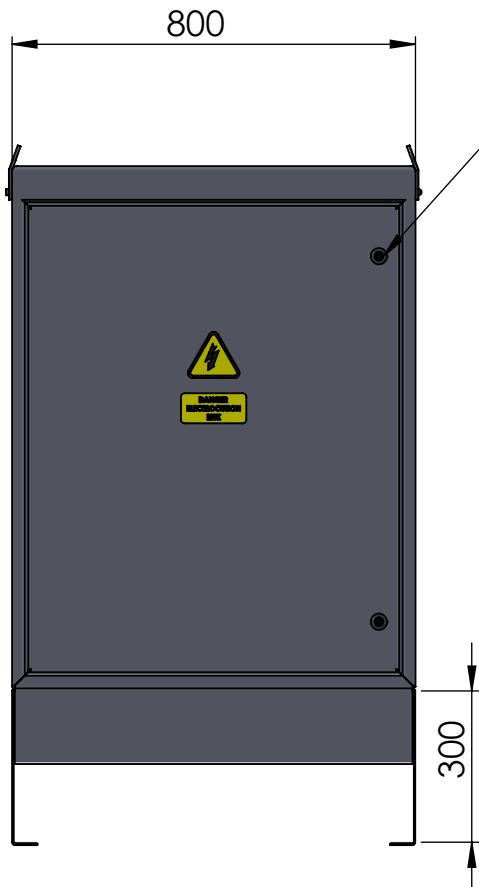

Base can be easily unbolted.

Base Bitumen paint over Galv.

EMAIL: seamus@sgsmechanical.net

MOBILE: 0876918435

DESCRIPTION:

SC 800,1000,450.



MATERIAL:  
See Part Drawing

WEIGHT Kg:  
204.6

Lifting Eyes.

Safety Decal to Required Spec.

Cell Sponge Rubber Sealing as Standard

Fixing Holes.

1/4 Turns, several options Available.

Base can be easily unbolted.

Base Bitumen paint over Galv.

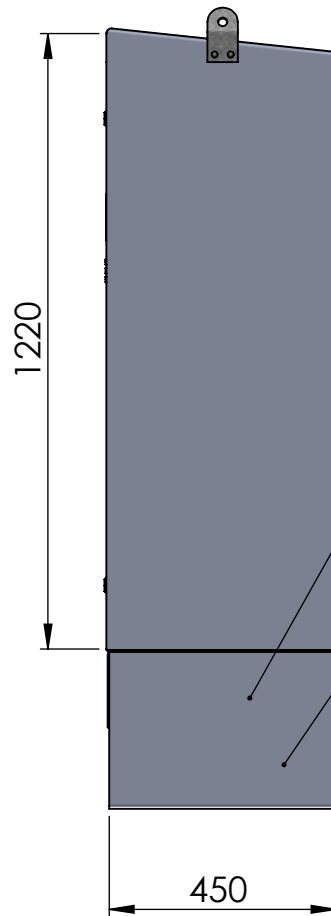
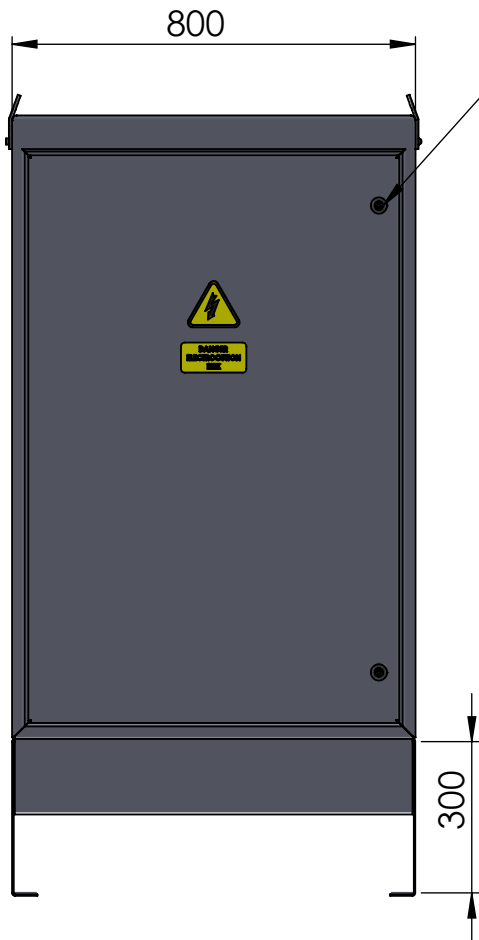
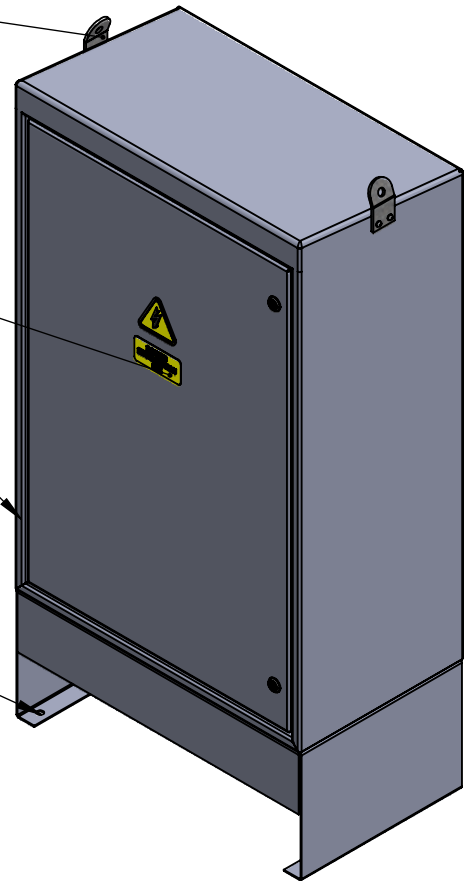
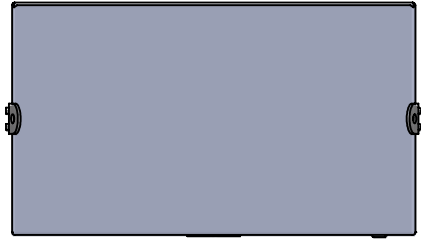

EMAIL: seamus@sgsmechanical.net

MOBILE: 0876918435

DESCRIPTION:

SC 800,1200,450.



MATERIAL:  
See Part Drawing

WEIGHT Kg:  
214.0



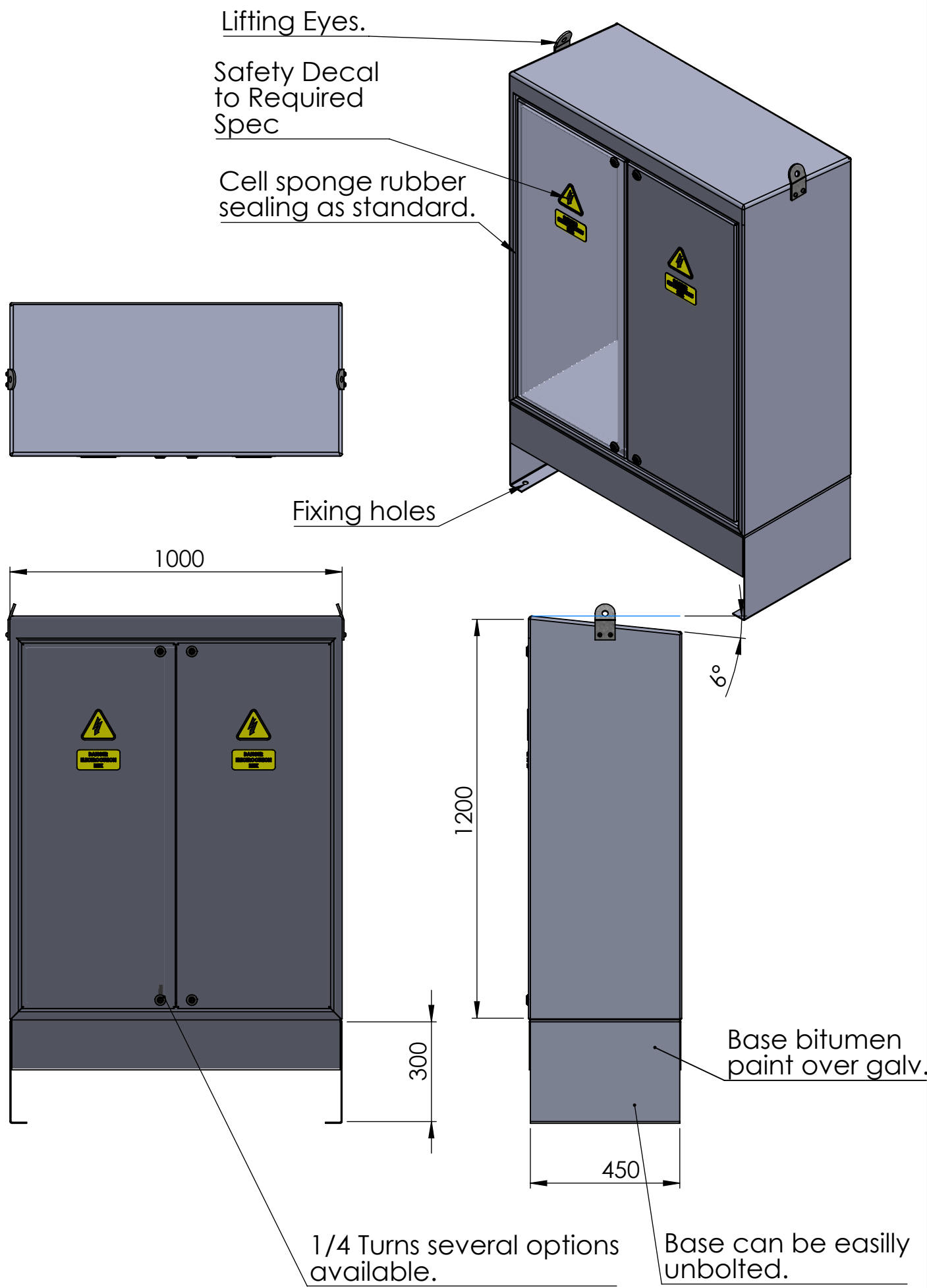

EMAIL: [seamus@sgsmechanical.net](mailto:seamus@sgsmechanical.net)

MOBILE: 0876918435

DESCRIPTION:

Double Compartment, 1000,1200,450



MATERIAL:  
See Part Drawing

WEIGHT Kg:  
260.5

Lifting Eyes.

Safety Decal to Required Spec

Cell sponge rubber sealing as standard.

Fixing holes

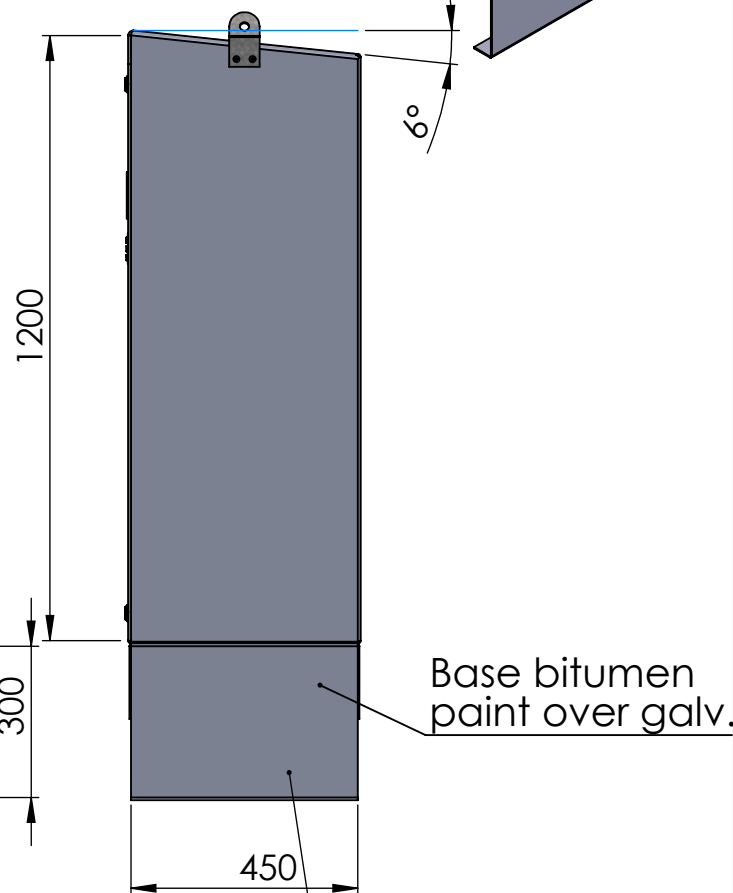
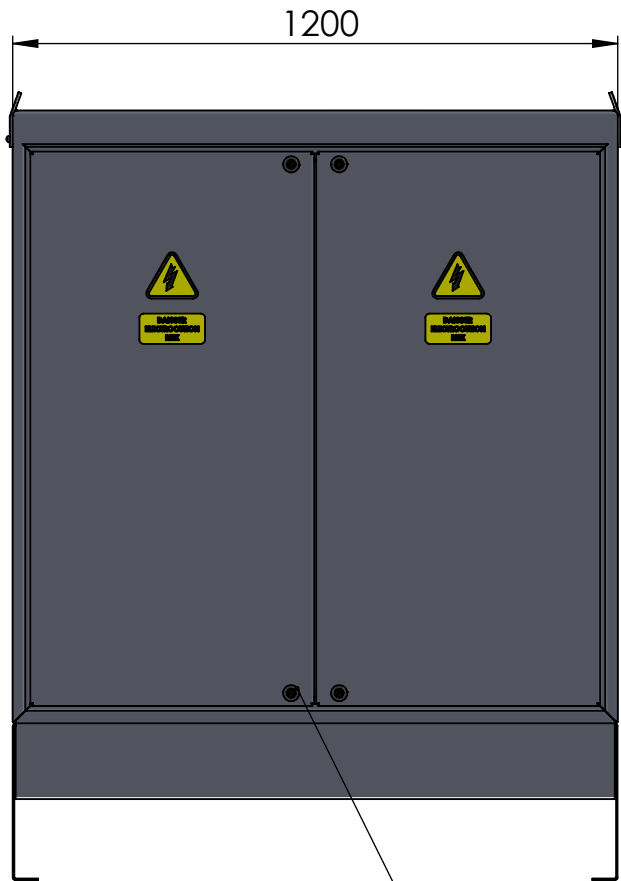
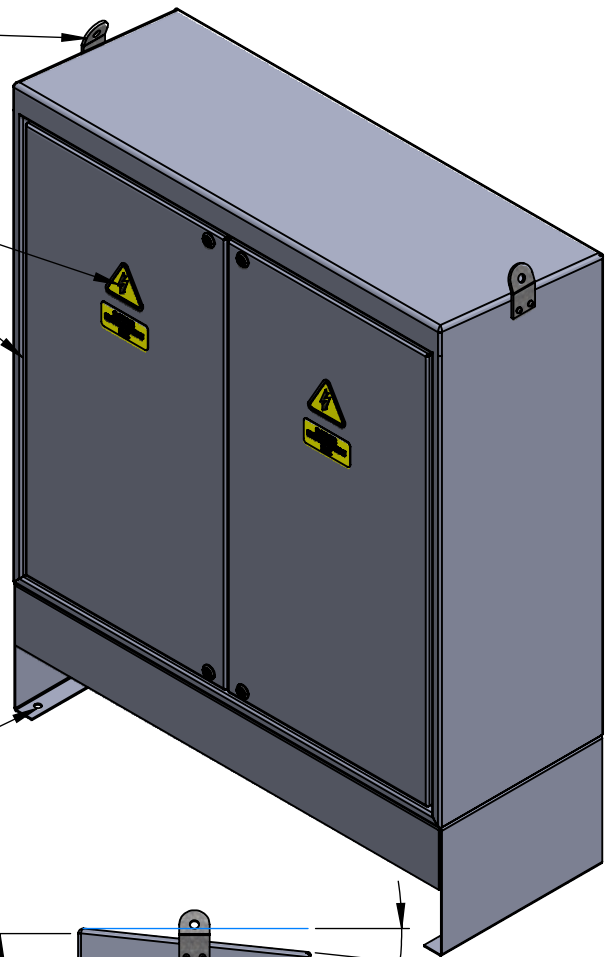
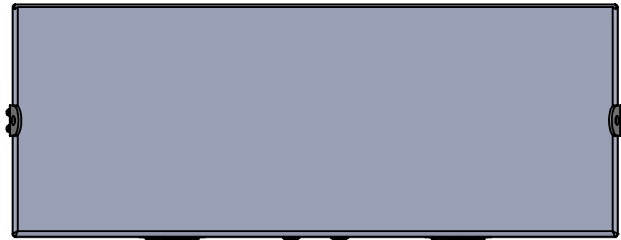

1/4 Turns several options available.

Base can be easily unbolted.

EMAIL: seamus@sgsmechanical.net

MOBILE: 0876918435

DESCRIPTION:

Double Compartment, 1200,1200,450



MATERIAL:  
See Part Drawing

WEIGHT Kg:  
304.6

Lifting Eyes.

Safety Decal  
to Required  
Spec

Cell sponge rubber  
sealing as standard.

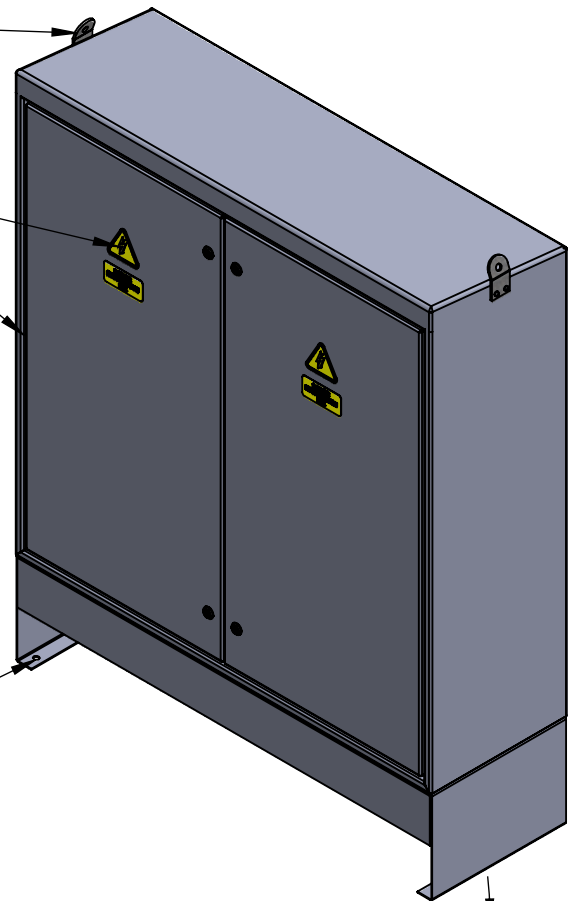

Fixing holes

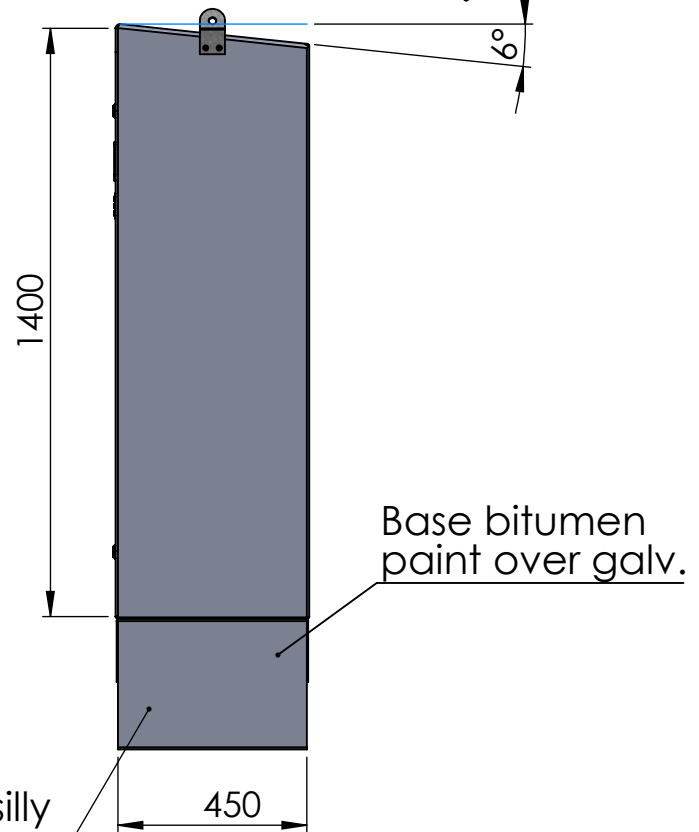
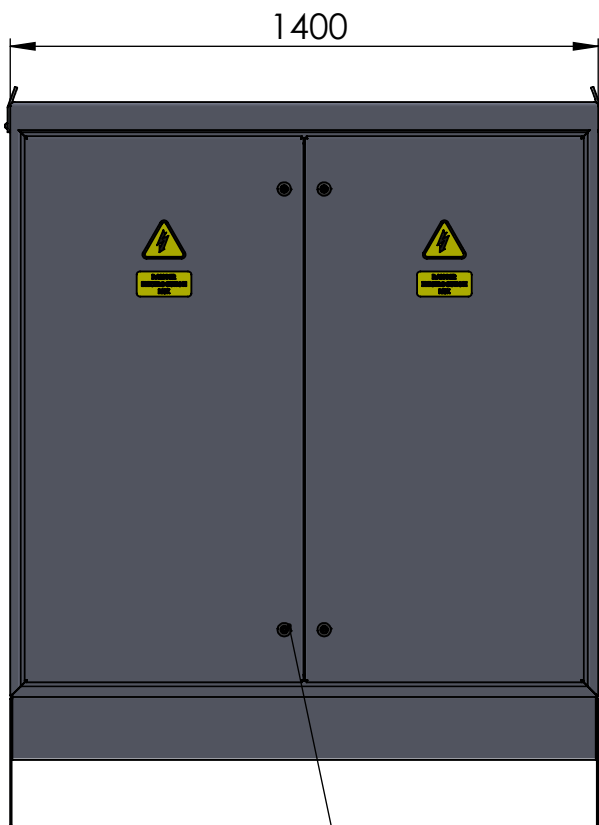

Base can be easilly  
unbolted.

1/4 Turns several options  
available.

EMAIL: seamus@sgsmechanical.net

MOBILE: 0876918435

DESCRIPTION:

Double Compartment, 1400,1400,450



MATERIAL:  
See Part Drawing

WEIGHT Kg:  
361.9

Lifting Eyes.

Safety Decal to Required Spec

Cell sponge rubber sealing as standard.

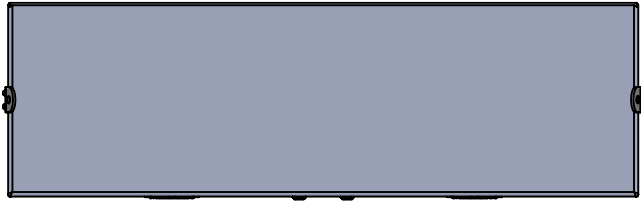
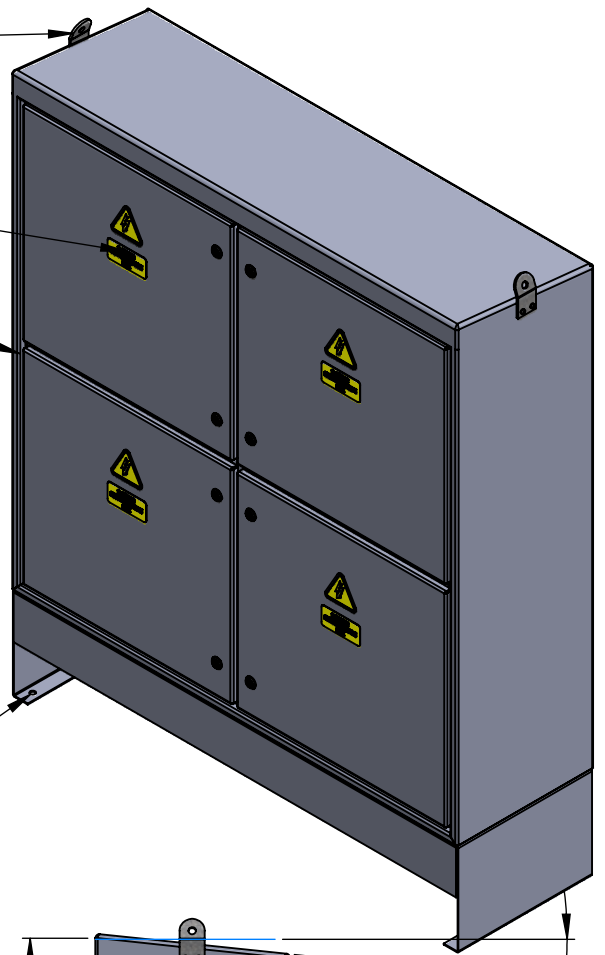

Fixing holes

1500

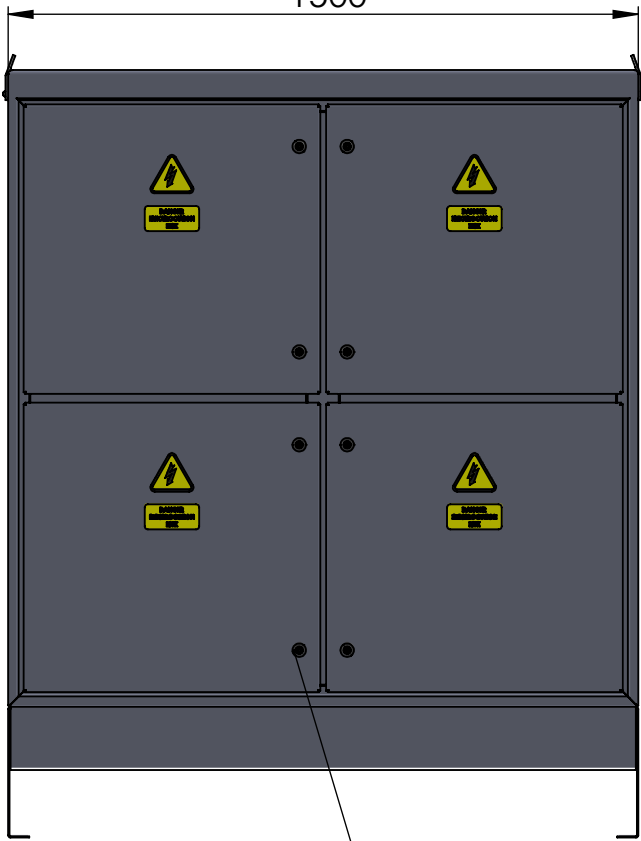

300

1/4 Turns, several options available

6°

1500

450

Base bitume paint over g

Base can be easily unbolted.

EMAIL: seamus@sgsmechanical.net

MOBILE: 0876918435

DESCRIPTION:

4C 1500,1500,450



MATERIAL:  
See Part Drawing

WEIGHT Kg:  
394.5

Lifting Eyes.

Safety Decal  
to Required  
Spec

Cell sponge rubber  
sealing as standard.

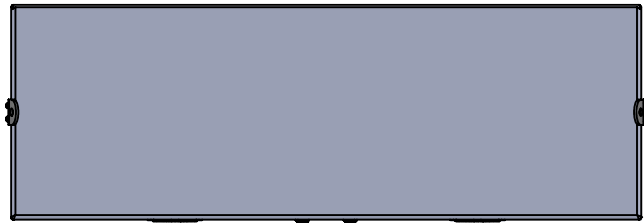
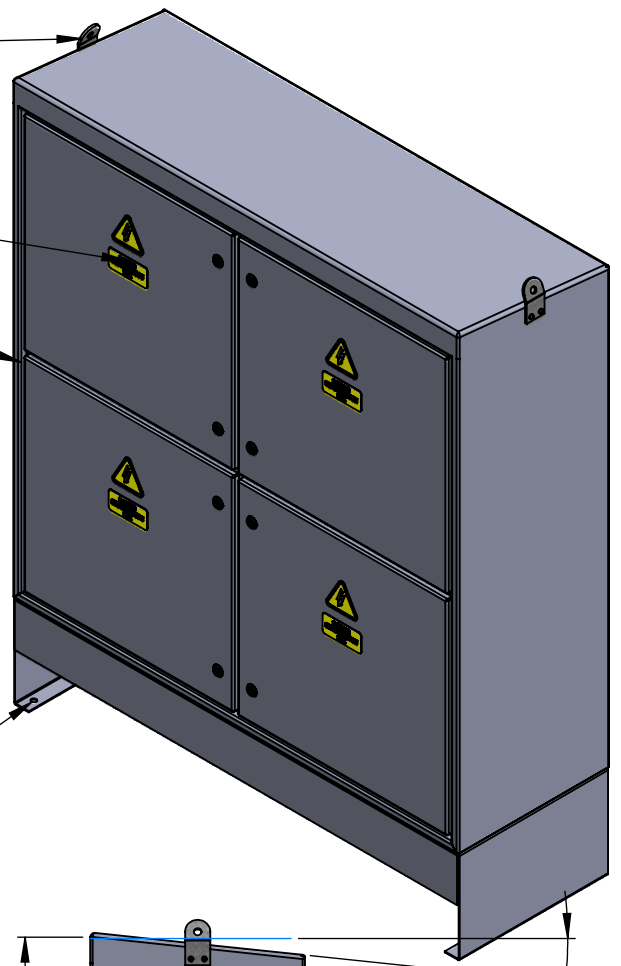

Fixing holes

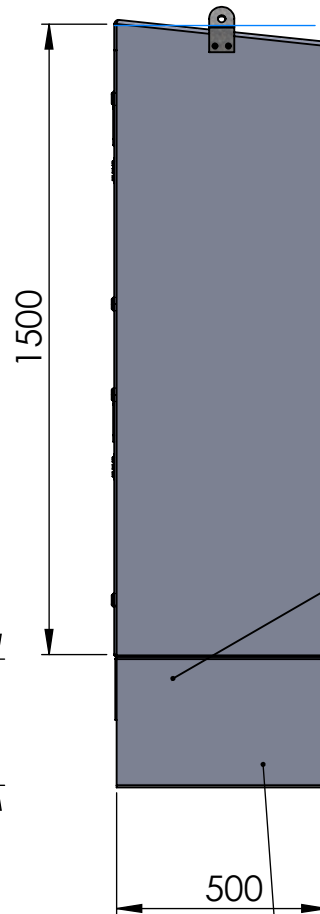

Base bitumen  
paint over galv.

1/4 Turns, several options  
available

Base can be easilly  
unbolted.

EMAIL: [seamus@sgsmechanical.net](mailto:seamus@sgsmechanical.net)

MOBILE: 0876918435

DESCRIPTION:

4C 1500,1500,500



MATERIAL:  
See Part Drawing

WEIGHT Kg:  
443.5